



14A Star Crescent, Hallam, Victoria, Australia, 3803.
Ph: (+61 3) 9796-4002 Fax: (+61 3) 9796-4003
Web: www.systemsinsight.com.au

Standard Generator Control Systems Synchronising Unit for Caterpillar Gen. Sets

*Product Bulletin -PSTD0005
June 2002*



Standard Generator Control Systems Synchronising Unit for Caterpillar Generator Sets

Systems Insight has designed a range of standard generator control systems to provide ready made, pre-engineered solutions to address frequently requested customer requirements.

A new 'add-on' paralleling control panel has been designed, for installation to Caterpillar generators fitted with an EMCP II+ control unit. The control panel features a manufactured cubicle which attaches to the rear of the EMCP II+ via lift-off hinges. The cubicle profiles the exact dimensions of the EMCP II+ and swings via the hinges to provide access to the rear compartment.

A control switch and push buttons are supplied, installed to the front of the EMCP II+ to provide operator control of paralleling operations.

The standard paralleling unit is designed to incorporate a Woodward DSLC (Digital Synchroniser & Load Control). The DSLC is connected via a 'Lonworks' communications network to other paralleled generators. Labelled terminals are provided for installation of network cabling by the site installer.

The DSLC is interfaced to the voltage regulator and engine speed control as part of the installation provided by Systems Insight.

LED indicator lights are also fitted to the fascia of the EMCP II+, to provide indication of 'Open' and 'Closed' status of the synchronising circuit breaker.

Operation:

The control selector and push buttons fitted to the front fascia of the EMCP II+ provide the operator with two paralleling control options:

Auto – Paralleling control is automatic when the generator is started via the remote start input on the EMCP II+. The DSLC is called to synchronise the generator with an external bus voltage reference as soon as the generator is started and nominal frequency is achieved. When in synchronism, the DSLC activates a 'close' pulse to call the external synchronising circuit breaker to close. When the circuit breaker is closed, the DSLC automatically ramps the generator onto the connected load.

When the remote start call signal is removed, the DSLC unloads the generator from the bus and activates an 'open' signal to call the external synchronising circuit breaker to open.

Manual – Paralleling control is manually initiated by an operator, when the generator is started either (a) via the local EMCP II+ control selector, or (b) via the remote start input on the EMCP II+.

A 'Sync. & Close' push button is fitted to the fascia of the EMCP II+. When the generator is started and nominal frequency is achieved the 'Sync. & Close' button may be held pressed to call the DSLC to synchronise the generator with an external bus voltage reference.

Standard Generator Control Systems - CAT Paralleling Control

When in synchronism, the DSLC activates a 'close' pulse to call the external synchronising circuit breaker to close. The 'Sync & Close' button can be released once the circuit breaker is closed.

When the circuit breaker is closed, the DSLC automatically ramps the generator onto the connected load.

An 'Unload & Open' push button is also fitted to the fascia of the EMCP II+.

When the 'Unload & Open' button is held pressed, the DSLC unloads the generator from the bus and activates an 'open' signal to call the external synchronising circuit breaker to open. The 'Unload & Open' button can be released once the circuit breaker is open.

For both Automatic and Manual control modes, a maintained 'open' command is signalled to the synchronising circuit breaker when the generator is stopped. The 'open' command is issued as soon as the run signal to the engine is removed.

A synchroniser alarm is generated by the DSLC on detection of a synchronising fault. This alarm is connected to a spare fault input on the EMCP II+ and programmed to indicate a synchroniser fault on the LCD display.

The paralleling system is designed to be adaptable for use with either air or motor operated synchronising circuit breakers, or with latching contactors.

Where motor operated circuit breakers are used, the control circuit to open the circuit breaker includes both a 24V shunt trip and a maintained, AC voltage pulse of 4 seconds duration, to motor the circuit breaker from the 'trip' to the 'off' position.

Mains Paralleling Option:

A variant to the standard CAT DSLC paralleling control panel is available, featuring facility to parallel the generator with the supply authority mains. This facility enables the operator to provide a 'no-break' transfer between normal mains and generator supply, dispensing with inconvenient and disruptive power interruptions. This feature is particularly useful on critical, interruption sensitive sites when returning to mains after operating on generator (as a result of an earlier mains outage). The facility can also be used to load test the generator, to 'soft' load and unload the generator to the building load without interrupting supply.

The mains paralleling version of this system includes the following additional items:

- ❖ Mains supply voltage sensing relay (3 phase).
- ❖ Micro PLC with 8 digital inputs, 4 analogue inputs and 6 relay outputs.
- ❖ Mains import power (kilowatts) sensing transducer with output to analogue PLC input.
(Provides an analogue process control reference to the PLC)
Note: Voltage and current references are derived from existing external CT's and VT's
- ❖ Additional labour allowance for commissioning of the installed system, extended to maximum 32 labour hours (local Melbourne Metro. Area – P.O.A. for other areas).

Standard Generator Control Systems - CAT Paralleling Control

Standard CAT Generator Paralleling Control Panel:

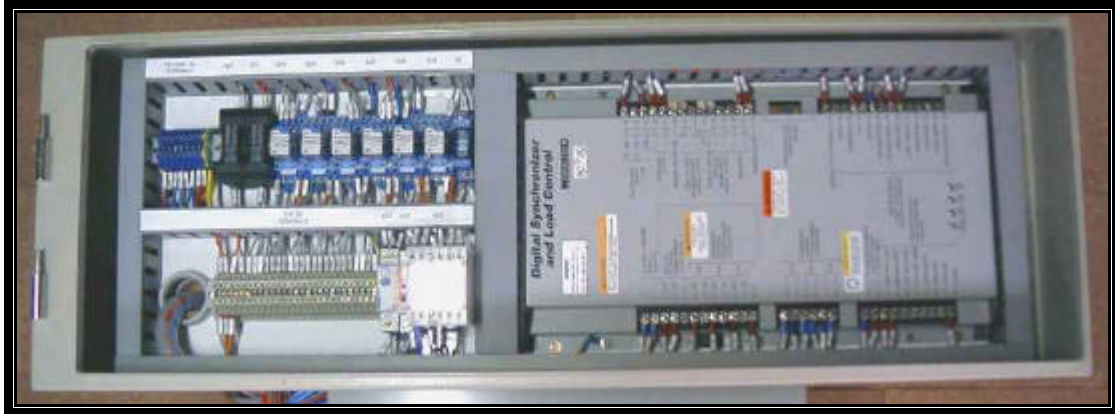

Wiring Schematics:

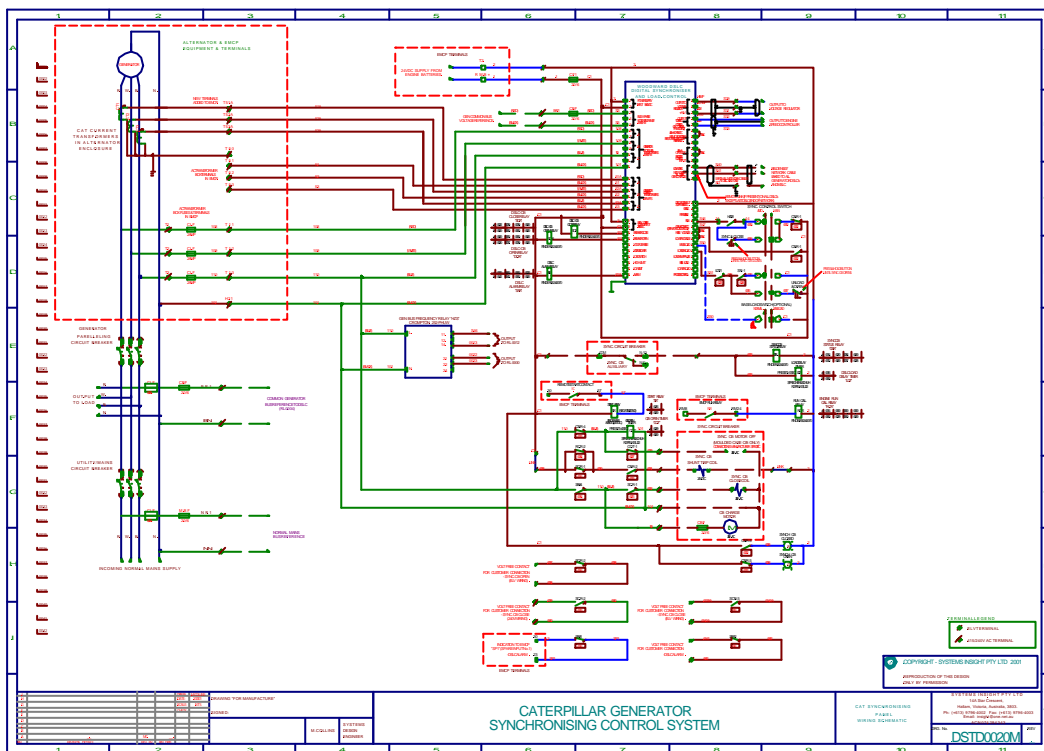

An electronically drafted wiring schematic (as shown above) is supplied with the standard Cat generator paralleling control system. All field installed cables interfacing to CAT terminals and new components are clearly highlighted, to assist with easy installation.

Standard Generator Control Systems - CAT Paralleling Control

Notes:

- ❖ Each system is inclusive of one complete synchronising control package per generator.
- ❖ Each system includes supply and installation of all equipment to a Cat generator set with EMCP II+ and maximum of 8 hours labour for load testing and commissioning. (32 hours for mains paralleling option)
- ❖ All installation and commissioning inclusions are based on works within the Melbourne Metropolitan area. Travel and other associated costs apply for interstate and overseas works.
- ❖ Where the mains paralleling option is employed, the local electrical supply authority may specify additional protection to operate during parallel operation of the generator with the mains. This additional protection is not included and would be priced and supplied separately.

Exclusions:

The following items are normally excluded from our standard package but are available as options:

- ❖ Provision of engine speed controller and voltage regulator (by generator supplier or customer)
- ❖ Provision and set-up of load banks for testing
- ❖ Local supply authority charges (in cases of mains parallel operation) are not included.
- ❖ Supply of electrical protection relays.